

EVALUATION AND MODIFICATION OF OPEN-WEB STEEL JOISTS AND JOIST GIRDERS



Marlon W. Broekemeier



James M. Fisher

MARLON W. BROEKEMEIER, P.E. is the Engineering Manager for Nucor Vulcraft Group located in Norfolk, Nebraska. He has an undergraduate degree in Civil Engineering from the University of Nebraska. He has over 23 years experience in the steel joist and deck industry encompassing design, software development, and management. He serves on the Steel Joist Institute Engineering Practice Committee and is a member of American Society of Civil Engineers and SSRC.

JAMES M. FISHER, Ph.D., P.E. is vice president of Computerized Structural Design (CSD), Milwaukee, Wisconsin. Dr. Fisher received his Bachelor of Science degree in civil engineering from the University of Wisconsin in 1962. He received his Master of Science degree and Ph.D. degree in structural engineering from the University of Illinois in 1965 and 1968 respectively. Dr. Fisher has specialized throughout his career in structural steel design and research. He has authored and co-authored four of the AISC Design Guides, as well as several books and many technical publications. Dr. Fisher is the Chairman of the AISC Committee on Specifications. Dr. Fisher also serves as the consulting engineer for the Steel Joist Institute and is active on numerous committees.

ABSTRACT

Open-web steel joists are used extensively in floors and roofs in many types of structures throughout the United States and other countries. Joists serve as an economical structural support, with millions of open-web steel joists and joist girders in service. Because of their wide use in steel framed buildings, there occasionally becomes a need to modify a joist or joist girder for various reasons, such as; the joists may have been damaged, or there may be a need to lengthen or shorten them, or there may be situations where additional loads are being added which may necessitate the need for reinforcement.

The Steel Joist Institute has introduced a new technical digest, TD #12, entitled "Evaluations and Modification of Open-Web Steel Joists and Joist Girders". In this Digest, methods and suggestions are provided which enables an engineer to evaluate joists or joist girders for modification or repair.

EVALUATION AND MODIFICATION OF OPEN-WEB STEEL JOISTS AND JOIST GIRDERS

MARLON W. BROEKEMEIER, P.E. and JAMES M. FISHER, Ph.D., P.E.

INTRODUCTION

Open web steel joists and joist girders occasionally must be evaluated for the addition of loads or other changes not known or considered in the original design of the joists or joist girders. There may be a need to strengthen or modify joists for the addition of roof top units, conveyors, snow drifting, field damage, or other added loads. The Steel Joist Institute (SJI) Engineering Practice Committee recognized there was a need for additional information on this topic for designers. Technical Digest #12 titled, Evaluation and Modification of Open-Web Steel Joists and Joist Girders (SJI 2007) fills this need. The Digest has a total of six chapters: Evaluation of existing joist strength, Methods of Supporting additional load, Design approaches for strengthening joists, Design approaches for modifying joists - shortening and lengthening, Other considerations, and a Summary chapter.

This paper introduces a few of the highlights from each chapter of the technical digest.

CHAPTER 1 EVALUATION OF EXISTING JOIST STRENGTH

Regardless of the reason for changes required to a joist, an evaluation will be needed to determine the existing joist strength. If the joist has been damaged in the field it may be much more apparent how the joist strength has been affected (See Figure 1). If load is added to existing joists, research will be required to determine the existing strength of the joist. There may be a chance that the joists may have been selected to carry a larger load than the originally specified design loads.



Figure 1 Joist End Diagonal Webs Inadvertently Cut During Construction

A number of items that may help determine the original design information include:

1. The original contract structural documents.
2. Final joist erection drawings used at time of construction.
3. The year the job was constructed.
4. The joist identification tag. The tag may give information regarding the manufacturer, year of construction, manufacturer's job number, mark number, and possibly a joist size. The tag is normally wired to a web member at one end of the joist.

The Steel Joist Institute has load tables and specifications available in the SJI 75-Year Joist Manual (SJI 2003). From the above four listed items, information denoting the joist designation may have been found. Using the

designation and the approximate year of manufacture, the SJI load tables can be used to obtain the uniform load capacity of the joist. If the joist designation is not known a field investigation will be required to determine the joist properties followed by an analysis of the joist member forces.

Whether information is obtained from records or if a field investigation is required, the following helpful and required information may be needed:

1. Loading on the joists (roof, floor, other)
2. Information from joist tags (the joist tag may give information regarding the manufacturer and the size of the joist)
3. Joist configuration (Warren, modified Warren, Pratt, other)
4. Joist span
5. Joist spacing
6. Joist depth
7. Seat depth (i.e. seat height)
8. Seat bearing condition (underslung or bottom)

The type of construction will also be needed since joist web and chord members will vary. For webs obtain dimensions including thicknesses and note:

- a. Rod webs (usually J-, H- and K-Series < 24" in depth)
- b. Crimped angle webs (usually J-, H- and K-Series > 24" in depth)
- c. Angles welded to the outside of the chords (some LH-Series and Joist Girders)
- d. Cold-formed sections
- e. End diagonal type
- f. Eccentricities
- g. Panel point spacing

For the chords obtain dimensions including thicknesses, separation distance along with identifying which members or panels contain fillers or ties and note:

- a. Double angles
- b. Cold-formed sections
- c. Rods
- d. Splices

The corresponding SJI design specifications for the joist series type should be used when analyzing the joist to determine the capacity. All webs are generally assumed to be pinned. A first order analysis is used.

CHAPTER 2 METHODS OF SUPPORTING ADDITIONAL LOAD

Once a preliminary analysis is made to see if the load carrying capacity of an existing joist is being exceeded, a determination needs to be made on how to best support the additional loading. Modifying the joist is not always the best option and many times it is either not practical or cost prohibitive to modify the joist. The first option that should always be looked at is to see how the load could be distributed so as not to exceed the capacity of any one joist. The second option would be to add new joists or beams to carry the added loads.

Load Distribution is an option if an additional member with suitable stiffness can be added either under the joist or through the joist as shown below in Figure 2.

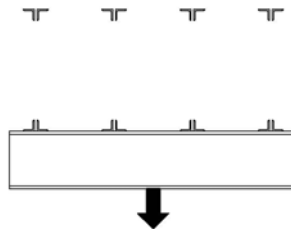

Figure 2 Load Distribution

The relative stiffness of the joists and the distribution beam is defined by the characteristic parameter beta as defined in Equation 2-1.

$$\beta = \sqrt[4]{\frac{(K/S)}{(4EI)}} \quad \text{Eq. 2-1}$$

Where,

- K = stiffness of the joist, kips/in.
- S = spacing of the joists, in.
- E = modulus of elasticity for the beam, ksi
- I = moment of inertia of the beam, in.⁴
- β = characteristic parameter, 1/in.

If S is less than $\pi/4\beta$, the spacing limit is not exceeded, and if the length of the beam is less than $1/\beta$, the beam may be considered to be rigid with respect to the supporting joists, and the reactions to the joists may be determined by static equilibrium.

Adding New Joists or Beams is a very good option when there are limited interferences such as piping, duct work, electrical conduits. Consideration needs to be given to camber and lateral stability of the top chord when a new joist is added. Joists can be supplied with seat depths that are shallower than the existing and also provided with a bolted splice at the center to facilitate the installation between existing joists in the field.

There are various ways to provide the lateral stability to the joist top chord. Attaching the joist top chord to the roof or floor deck can be accomplished with mechanical fasteners or welding. The method used depends on whether there is access from above, what is on the deck and if there is only access from below. When the chords cannot be attached to the deck, additional top chord bridging can be added to provide the lateral stability required.

CHAPTER 3 DESIGN APPROACHES FOR STRENGTHENING JOISTS

When load distribution or adding new joists or beams is not an option, strengthening the joists can be explored. If the preliminary analysis shows that both the chords and webs are overstressed, it is often difficult to strengthen or reinforce the joists. Access to the joists and also field conditions must be taking into account when deciding if it is possible to modify the joist in the field. Making good vertical or overhead welds on existing joists is difficult and requires experienced qualified welders.

Once it is determined to explore modification, two design approaches are generally used:

Approach I: Ignore the existing strength of the member. This approach is conservative and normally used for web reinforcement. Simply design the reinforcing members to carry the total load.

Approach II: Make use of the strength of the existing member. This approach is normally used for the reinforcement of the chords since they are typically much larger than the web members. The applied forces are distributed between the existing member and the reinforcing member in direct proportion to their areas.

For either approach it is best to shore the joist since welding can cause a temporary loss of strength while under load. Transverse field welds on members should always be avoided. Reinforce with the dead and live loads removed when possible. Jacks located at panel points of the joist can be used to take load off such that the preload is zero. The following describes the latter approach in more detail:

Terminology and terms used for Approach II:

A_e = area of existing member, in.²

A_r = required area of reinforcing, in.²

A_t = area of existing member plus the area of the furnished reinforcing, in.²

A_{fr} = area of the furnished reinforcing, in.²

A_{tr} = total area required (existing member and required reinforcing), in.²

F_{ye} = specified minimum yield stress of existing member, ksi.

P_o = original force for the existing member (original design force), kips.

P_p = preload in the existing member at the time of reinforcing, kips.

P_r = force in the reinforcing member, kips.

P_t = required strength, kips.

P_{rw} = required strength in the reinforcing member weld, kips.

f_p = stress from preload in the existing member, ksi.

For Approach II, it is assumed that applied forces are distributed between the existing member and the reinforcing member in direct proportion to their areas. Any preload force in the existing member must be considered. If the joists are shored and jacked up to remove the existing load, then the preload is zero, otherwise the preload can be calculated based on the load present at the time of reinforcing. Shoring and placement of the jacks is the responsibility of the Specifying Professional.

Design of reinforcing for tension members (Approach II):

1. Determine the total area required, A_{tr} .

If the force in the existing member is limited to the original required strength in the member, the following equation applies. Using this procedure the initial welds, as provided by the joist manufacturer, are not increased.

$$P_p + (P_t - P_p) \left(\frac{A_e}{A_{tr}} \right) \leq P_o \quad \text{Eq. 3-1}$$

Thus,

$$A_{tr} = \left(\frac{P_t - P_p}{P_o - P_p} \right) A_e \quad \text{Eq. 3-2}$$

It should be noted that the equation assumes that the existing steel and the reinforcing steel both have equal yield strength. There are several design procedures to accommodate the fact that the yield strengths of the two materials may not be equal. These include:

- Assume both materials have the same yield strength as the yield strength of the lowest material used. This is the most conservative method.
- Use the actual yield strength of each material in the design. Allow each material to achieve the full allowed stress level.

2. The required area of reinforcing equals

$$A_r = A_{tr} - A_e \quad \text{Eq. 3-3}$$

3. The force in the reinforcing member equals

$$P_r = \left(\frac{A_{fr}}{A_r} \right) (P_t - P_p) \quad \text{Eq. 3-4}$$

Alternately, the weld on the existing member can be reinforced to take the entire axial load, provided an adequate force path exists to transfer the force in the reinforcing member to the weld.

Design of reinforcing for compression members (Approach II):

1. Select a trial reinforcing member.
2. Check the buckling strength of the composite member. If a preload force exists, first determine the magnitude of the compressive stress in the existing member due to the preload, f_p . For the buckling check, use F_y as the minimum of $(F_{ye} - f_p)$, and F_y of the reinforcing member.
3. Design the weld for the reinforcing member. The force in the weld is

$$P_{rw} = \left(\frac{A_{fr}}{A_t} \right) (P_t - P_p) \quad \text{Eq. 3-5}$$

Or, as previously mentioned, the weld on the existing member can be reinforced to take the entire axial load provided an adequate force path exists to transfer the force in the reinforcing member to the weld.

Chord Reinforcement

There are a number of different options available to reinforce the chord members. Figures 3.1 thru 3.4 show several details that have been used successfully to reinforce top chords of joists.

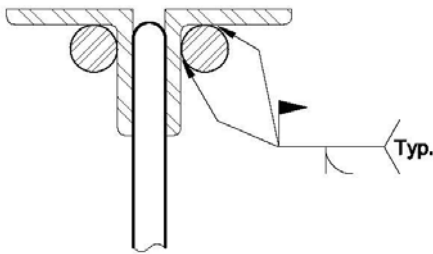

Figure 3.1 Top Chord Reinforcement – Rods

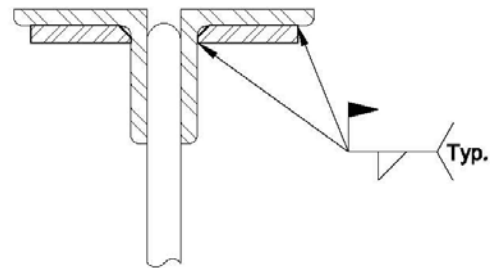

Figure 3.2 Top Chord Reinforcement - Plates

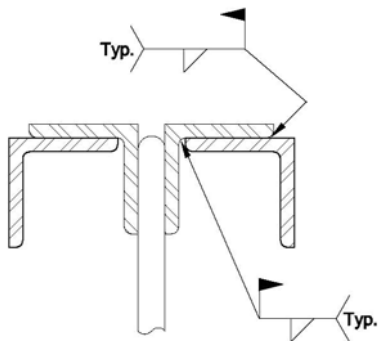

Figure 3.3 Top Chord Reinforcement – Angles

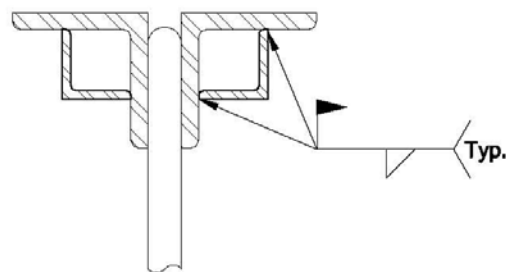

Figure 3.4 Top Chord Reinforcement - Angles

A simple reinforcement for the bottom chord of the joist is also shown in Figure 3.9. Sufficient weld needs to be placed at panel points to transfer the required strength into the existing chords and into the chord reinforcement. If a rod reinforcement is used for a tension chord such as the bottom chord, the rod would need to be spliced such as that shown in Figure 3.8.

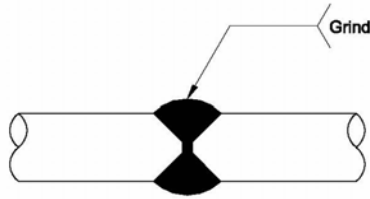

Figure 3.8 Rod Splice

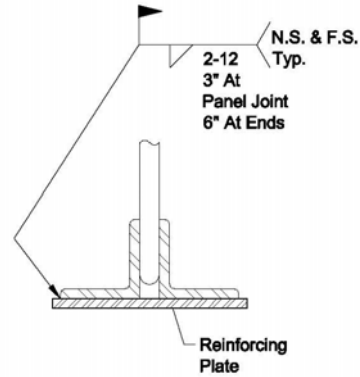

Figure 3.9 Bottom Chord Reinforcement

Web Reinforcement

There are basically three types of webs used in most joists:

- 1) Rod web members placed between the chord angles.
- 2) Crimped web members placed between the chord angles that have the ends crimped to fit in the 1" gap between the chord angles.
- 3) Double angle web members that attached to the vertical legs of the chord angles.

Typical reinforcement is shown in Figures 3.10, 3.12, 3.19, and 3.21 below:

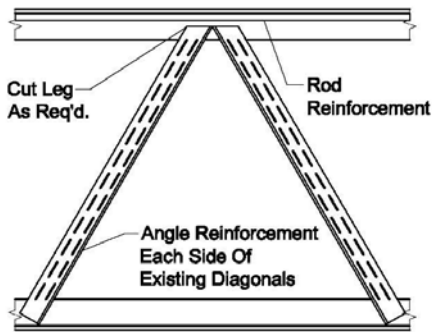

Figure 3.10 Angle Reinforcement on Rod Web Joist

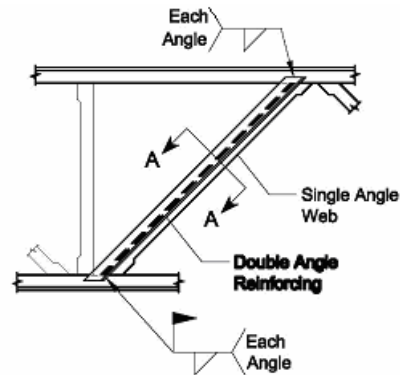

Figure 3.12 Crimped Web Reinforcement

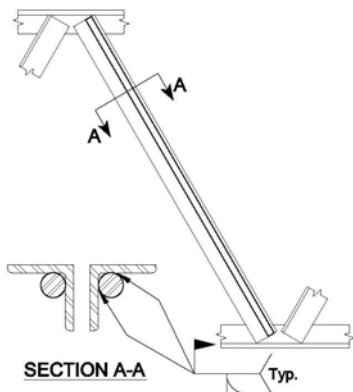

Figure 3.19 Rod Reinforcing

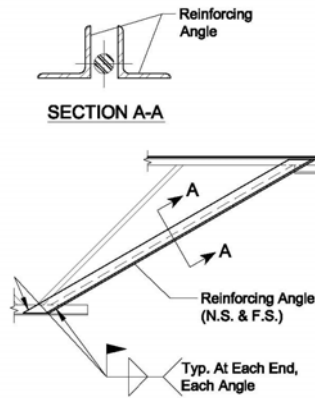

Figure 3.21 End Diagonal Reinforcing

EXAMPLE: Strengthening of a LH-Series joist with double angle webs

This example illustrates reinforcing of double angle webs of a LH-Series open web steel joist. As part of a tenant remodel it was required that additional equipment be installed on the joists. The original joists were designated 32LH780/440 with a live load deflection limitation. The added equipment was to be centered over two joists with a resulting load of 2000 lbs. located at 7'-4" and 12'-3" from the tag end. Shown in Figure 3.39 is a typical joist loading diagram. The uniform loads shown in the designation are the original design loads.

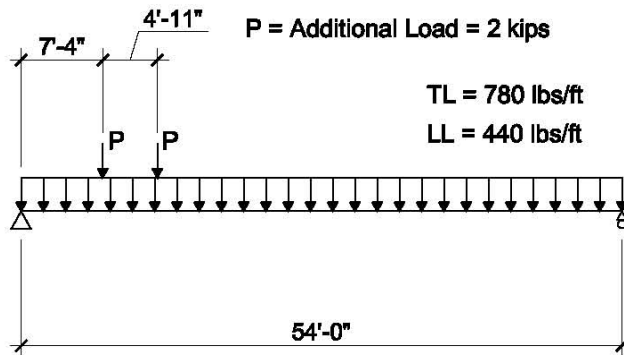

Figure 3.39 32LH780/440

The load distribution method of verifying steel joists was not a feasible solution the joists were originally designed for only the design loads with no reserve for distribution. Due to other interferences, adding new joists or beams was also not possible. Joist reinforcing was the best solution. An analysis indicated that the top and bottom joist chords were not overstressed since they were controlled by the original live load deflection limitation. However, a few webs were slightly overstressed.

The joist has a design span that equals 54'-0" and a total depth of to 32 inches. The panel points are 29 1/2" inches on center. The top and bottom chords are comprised of 3 1/2" x 3 1/2" double angles. The webs which are overstressed are double angles. The yield strength, $F_y = 50$ ksi for all members in the joists. Through analysis it was found that the required axial force in the end web (W2) is 60.5 kips while the allowable force in this member, obtained from the joist manufacturer, is 56.3 kips. The first compression web member (W3) required force is 18.1 kips and its allowable web force, obtained from the manufacturer, is 17.2 kips. Since the joists were originally designed using Allowable Stress Design (ASD), those same procedures were used to determine the required reinforcement. Approach II will be used in this example.

End Web Reinforcing:

The load in the end tension web (W2) at the time of reinforcing is 23.0 kips.

Total area required = $A_{tr} = \frac{P_t - P_p}{P_o - P_p} A_e$ where:

- $P_t = 60.5$ kips (required force)
- $P_p = 23.0$ kips (preload force)
- $P_o = 56.3$ kips (original allowable design force)
- $A_e = 1.876$ in.² (area of existing two 2 x 2 x 0.250 web angles)

Thus, $A_{tr} = \frac{(60.5 - 23.0)}{(56.3 - 23.0)} (1.876) = 2.113$ in.²

The required area of reinforcing equals

$$A_r = A_{tr} - A_e = 2.113 - 1.876 = 0.237 \text{ in.}^2$$

Adding round rods works well for double angle reinforcement so use 2- 3/4" diameter rods in the heel of the angles.
Area of furnished reinforcing,

$$A_{fr} = \frac{2\pi(d)^2}{4} = \frac{2\pi(0.75)^2}{4} = 0.884 \text{ in.}^2 > 0.237 \text{ in.}^2 \quad \text{Therefore, OK}$$

The total area, A_t , is the sum of the areas of the existing web angles plus the areas of the reinforcing rods,

$$A_t = A_e + A_{fr} = 1.876 + 0.884 = 2.760 \text{ in.}^2$$

The force in the reinforcing member equals:

$$P_r = \left(\frac{A_{fr}}{A_t} \right) (P_t - P_p) = \left(\frac{0.884}{2.760} \right) (60.5 - 23.0) = 12.01 \text{ kips}$$

Check the stress in round rod reinforcing member: $F = P/A = 12.01/0.884 = 13.59 \text{ ksi} < 21.6 \text{ ksi}$

Therefore, the use of A36 material is **OK**.

The joint between the rod and angle will be a partial-joint-penetration groove weld and will have an effective throat thickness of (5/16) times the rod radius (see AISC Specification Table J2.2 for a Flare Bevel Groove weld), thus the effective throat equals 0.117 in. The allowable shear per weld using E70 electrodes ($F_{EXX} = 70 \text{ ksi}$) from the AISC Specification Table J2.5, Available Strength of Welded Joints (AISC 2005) is 2.46 kips/in.

The total length of weld required to develop the force in the rod equals $12.01/2.46 = 4.88 \text{ in.}$

The 6 in. of weld shown in Figure 3.40 at the ends of each reinforcing rod is more than adequate. Between the end welds, the round rods are stitch welded 2 in. at 12 in. center-to-center. This pattern is used as a practical limitation to limit the slenderness ratio between connectors.

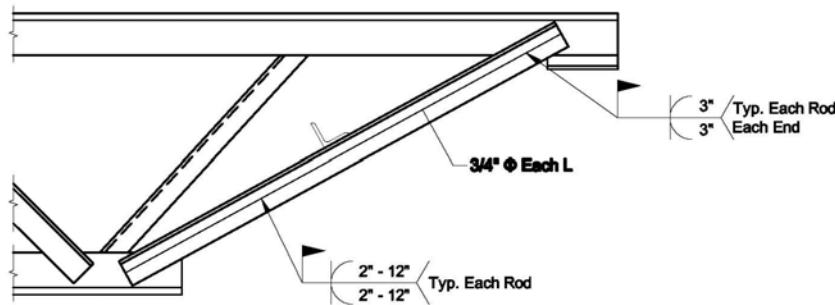

Figure 3.40 Reinforcing of End Diagonals

The welded connection between the web angles and the chord angles must also be checked for the total required force, $P_t = 60.5 \text{ kips}$.

Based on 3/16 in. fillet welds with E70 electrodes, the allowable shear per inch of weld equals $(0.707)(0.188 \text{ in.})(21 \text{ ksi}) = 2.79 \text{ kips/in.}$ Thus, $60.5/2.79 = 21.7 \text{ in.}$ (use 11 in. at each end of each web angle). If 11 in. of weld does not exist then additional weld needs to be added. A check must also be made for tensile rupture. Conservatively U can be taken as 0.6, or U can be determined from the AISC Specification Table D3.1, Shear Lag Factors for Connections to Tension Members. If one uses Case 2, the value of U depends on the arrangement of the welds. The AISC Specification does not address the condition where unequal weld lengths are used on the heel and the toe of the angle. The author suggests that the length of the weld along the heel of the angle be used for the determination of U . For this example assume that 4 inches of weld are along the heel and 7 inches are along the toe of the angle.

$$U = 1 - \frac{\bar{x}}{l} \quad \text{Case 2}$$

Where:

\bar{x} is the centroid location for the composite section comprised of web angle plus the round rod and l is the length of the connection.

The nominal strength P_n based on tensile rupture equals $F_u A_e$ or $U F_u A_t$.

Since the weld is placed on the angle in the connection to the chords F_u can be taken as 65 ksi. and \bar{x} can conservatively be taken at the centroid location of the round rod, thus \bar{x} equals $(0.25 + 0.375) = 0.625$ in.

$$U = 1 - \frac{\bar{x}}{l} = 1 - \frac{0.625}{4} = 0.844$$

$$P_n = U F_u A_t = (0.844)(65)(2.760) = 151.4 \text{ kips}$$

$$P_{\text{available}} = P_n / \Omega_t = 151.4 / 2.00 = 75.71 \text{ kips} > 60.5 \text{ kips} \quad \text{Therefore, OK}$$

First Compression Web Reinforcing

The load in the first compression web (W3) at the time of reinforcing is 6.9 kips.

Design Approach:

1. Select a trial reinforcing member.
2. Determine the composite section properties of the reinforcing member and the existing member.
3. Check the buckling strength of the composite web section. First determine the magnitude of the compressive stress in the existing member due to the preload, f_p . For the buckling check, use F_y as the minimum of $(F_{ye} - f_p)$, and F_y of the reinforcing member.
4. Design the weld size and length for the reinforcing member. The force in the weld is:

$$P_{rw} = \left(\frac{A_{fr}}{A_t} \right) (P_t - P_p) \quad \text{Eq. 3-5}$$

5. Check local buckling of the reinforcing member.

Solution:

1. Trial reinforcing member: Try using two 3/4 in. diameter rods, $F_y = 36$ ksi
2. Determine the composite properties of the combined section shown in Section A-A of Figure 3.41:

The total area, A_t , is the sum of the areas of the existing web angles plus the areas of the reinforcing rods,

$$A_t = A_e + A_{fr} \quad \text{Eq. 3-6}$$

Area of the existing 1.5 x 1.5 x 0.138 web angles = $A_e = 2(0.395) = 0.790 \text{ in}^2$.

Area of furnished reinforcing, $A_{fr} = 2\pi d^2 / 4 = 2(0.442) = 0.884 \text{ in}^2$

$$A_t = 0.790 + 0.884 = 1.674 \text{ in}^2$$

The location of the centroid of the composite section with respect to the x-axis is:

$$\bar{y} = \frac{1}{A} \sum A_i \bar{y}_i \quad \text{Eq. 3-7}$$

$$\bar{y} = 1/1.674 [(0.884)(0.138+0.375)+(0.790)(0.426)] = 0.472 \text{ in.}$$

The moment of inertia of the composite section with respect to the x-axis is:

$$I_x = \sum (I_i + A_i d_i^2) \quad \text{Eq. 3-8}$$

$$I_x = 2[0.085 + 0.395(0.426 - 0.472)^2 + 0.016 + 0.442(0.513 - 0.472)^2] = 0.205 \text{ in.}^4$$

The radius of gyration of the composite section with respect to the x-axis is:

$$r_x = \sqrt{\frac{I_x}{A_t}} \quad \text{Eq. 3-9}$$

$$r_x = \sqrt{\frac{0.205}{1.674}} = 0.350 \text{ in}$$

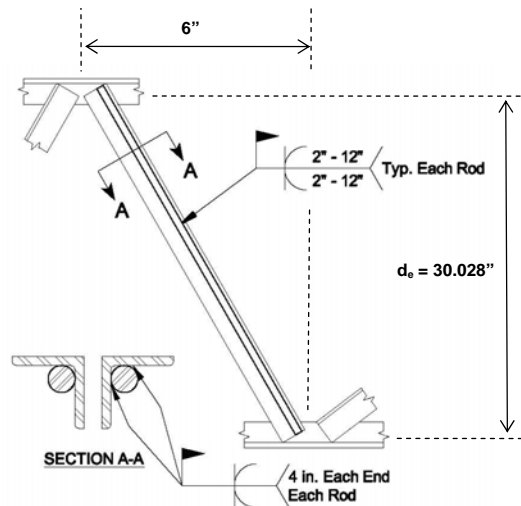

Figure 3.41 Double Angle Reinforcing with Rod

3. Check the buckling strength of the composite web section:

For the compression webs, the allowable load is determined using the AISC Specification Chapter E (AISC 2005). Fillers are used between the two angles thus the provisions for single angles are not required.

$$P_c = F_a A_t \quad \text{Eq. 3-10}$$

where:

P_c is the allowable compression strength, P_n / Ω_c , kips.

F_a is the allowable compressive stress, F_{cr} / Ω_c , ksi

A_t is the composite member cross-sectional area, in^2 .

Safety factor, $\Omega_c = 1.67$

Determine a yield stress to be used for the reinforcement design:

Preload, $P_p = 6.9$ kips

$$f_p = \frac{6.9}{(2)(0.395)} = 8.73 \text{ ksi}$$

Yield stress to be used is the minimum of:

$$F_{ye} - f_p = 50 - 8.73 = 41.27 \text{ ksi, and } F_y = 36 \text{ ksi for the rods.}$$

Thus, use 36 ksi.

$$\text{When } \frac{b}{t} \leq 0.45 \sqrt{\frac{E}{F_y}} \quad Q_s = 1.0 \quad (\text{AISC E7-10})$$

$$\frac{1.5}{0.138} = 10.87 \leq 0.45 \sqrt{\frac{E}{F_y}} = 0.45 \sqrt{\frac{29000}{36}} = 12.77 \quad Q_s = 1.0$$

$$\text{When } \frac{KL}{r} \leq 4.71 \sqrt{\frac{E}{QF_y}} \quad F_{cr} = Q \left[0.658 \frac{F_y}{F_e} \right] F_y \quad (\text{AISC E3-2})$$

$$\text{When } \frac{KL}{r} > 4.71 \sqrt{\frac{E}{QF_y}} \quad F_{cr} = 0.877 F_e \quad (\text{AISC E3-3})$$

$$F_e = \frac{\pi^2 E}{\left(\frac{KL}{r} \right)^2} \quad (\text{AISC E3-4})$$

Compute the slenderness ratio of the composite section. Use an unsupported length based on the effective depth of the joist and the horizontal panel length as shown in Figure 3.41 with an effective length factor $K=1.0$.

$$L = \sqrt{(6)^2 + (30.028)^2} = 30.62 \text{ in.}$$

$$\frac{L}{r} = \frac{30.62}{0.350} = 87.49 < 4.71 \sqrt{\frac{29000}{36}} = 133.68$$

$$F_e = \frac{\pi^2 (29000)}{\left(\frac{30.62}{0.350} \right)^2} = 37.39 \text{ ksi}$$

$$F_{cr} = 1.0 \left[0.658 \frac{36}{37.39} \right] 36 = 24.06 \text{ ksi}$$

The available compressive axial stress is:

$$F_a = F_{cr} / \Omega_c = 24.06 / 1.67 = 14.41 \text{ ksi}$$

And, the available compressive force is:

$$P_c = (14.41)(1.674) = 24.12 \text{ kips} > 18.1 \text{ kips required} \quad \text{Therefore, OK}$$

4. Design the welds:

The total force in the welds determined by Equation 3-5:

$$P_{rw} = \left(\frac{A_{fr}}{A_t} \right) (P_t - P_p) = \left(\frac{0.844}{1.674} \right) (18.1 - 6.9) = 5.91 \text{ kips}$$

Alternately, each of the 3/4 in. diameter rods has an allowable force of $(14.41)(0.442) = 6.37$ kips. This force will be used for the weld design.

The joint between the rod and angle will be a partial-joint-penetration groove weld and will have an effective throat thickness of (5/16) times the rod radius (see AISC Specification Table J2.2 for a Flare Bevel Groove weld), thus the effective throat equals 0.117 in. The allowable shear per weld using E70 electrodes ($F_{EXX} = 70$ ksi) from the AISC Specification Table J2.5, Available Strength of Welded Joints (AISC 2005) is 2.46 kips/in.

The total length of weld required to develop the force in the rod equals $6.37/2.46 = 2.59$ in.

The 4 in. of weld shown in Figure 3.41 at the ends of each reinforcing rod is more than adequate. Between the end welds, the round rods are stitch welded 2 in. at 12 in. center-to-center. This pattern is used as a practical limitation to limit the slenderness ratio between connectors.

5. Check buckling of the reinforcing:

Check buckling of the 3/4 in. diameter reinforcing rod between welds.

$$L = \text{weld spacing} - \text{weld length} = 12 - 2 = 10 \text{ in.}$$

$$r = \sqrt{\frac{I}{A}} = \sqrt{\frac{0.0155}{0.422}} = 0.187$$

Slenderness ratio of the rod is

$$\frac{L}{r} = \frac{10}{0.187} = 53.4$$

$$F_e = \frac{\pi^2(29000)}{\left(\frac{10}{0.187} \right)^2} = 100.09 \text{ ksi}$$

$$F_{cr} = 1.0 \left[0.658^{\frac{36}{100.09}} \right] 36 = 30.97 \text{ ksi}$$

The available compressive axial stress is:

$$F_a = F_{cr}/\Omega_c = 30.97/1.67 = 18.54 \text{ ksi}$$

And, the available compressive force is:

$$P_c = (18.54)(1.674) = 31.04 \text{ kips} > 18.1 \text{ kips required} \quad \text{Therefore, OK}$$

CHAPTER 4 DESIGN APPROACHES FOR MODIFYING JOISTS - SHORTENING AND LENGTHENING

For various reasons there are occasions when a joist either needs to be lengthened or shortened. Lengthening by any amount can result in a large increase in chord forces. Shortening a joist is a simpler modification than is lengthening since no extra material needs to be spliced onto the chord. Since the joist is becoming shorter, the chord is usually oversized because of the reduced axial forces. However, any change in length of a joist can result in web stress reversals and must be investigated. The web members are typically comprised of angles or rounds that are designed with smaller members the closer they are to the point of the shear inflection on the joist. In addition, any removal of a main diagonal web such as the end web can cause a loss of some of the joist camber. Maintaining camber during the modification should not be overlooked.

Typically when multiple joists require modification it is quite often less expensive to install new joists. The advantage becomes greater the smaller the joists are. Replacement joists can usually be supplied much more quickly than the accumulative time it takes to design the reinforcing, purchase and deliver the reinforcing materials, and the time to repair the joist. In addition, there is not the concern for the quality of a repair done in the field which may be made under less than desirable conditions. With any field modification, proper inspection must be conducted to ensure the modification was done correctly and with good quality. When adding additional web members to the joist, it is very important to intersect the web members such that eccentricity is as little as physically possible. This may require reinforcing angles to be rotated with their outstanding legs in a direction that will best accommodate this.

Another option that may be better than shortening or lengthening the joists would be to investigate if it is possible to modify or relocate the support for the joists. There are many situations where this is a much better option so this option should also not be overlooked.

Example: Shortening of a Joist

A 39 ft.-10 ½ in. long 24K8 is to be shortend by 10 in. The joist is shown in Figure 4.1.

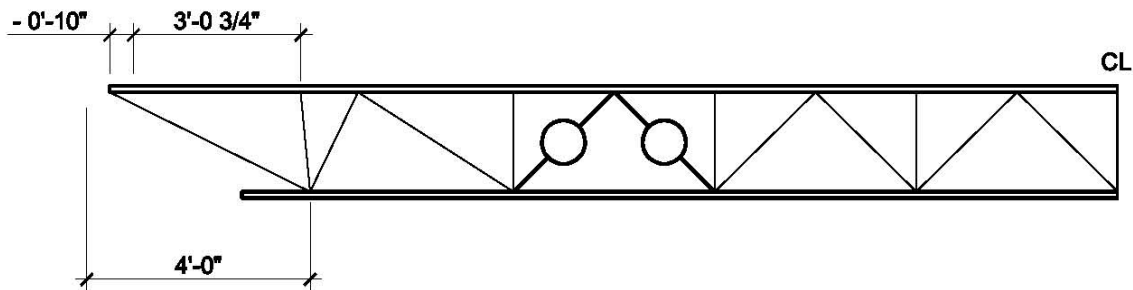

Figure 4.1 Joist to be Shortened

1. Approximate angle of new end web:
 $\theta = \arctan (48-10)/24 = 57.7$ degrees
2. From the load tables the new SJI load = 293 plf.
3. Analysis indicates that the two circled web members are overstressed, therefore reinforce as needed. This joist has crimped angle web members thus a pair of angles on the outside of the chords in line with the existing web is workable for strengthening.
4. There is a 1-inch gap between the top chord angles and the seat is 2 ½ inches deep. Use a pair of 2 x 2 x 3/8 x 4 in. angles welded together back-to-back and welded to the chords to form the seat.
5. From analysis the new end web force is 10050 lbs. The new end web length (based on clear length between 2 in. top chord and 1 ¾ in. bottom chord) is 37.7 inches. A pair of ¾ in. round bars will satisfy strength and

slenderness criteria (240 per the SJI Specification for K-series joists). Using E70XX electrode, weld strength of flare bevel weld with 3/4 round is 2460 lbs per inch. Each end of each bar requires 2 1/4 in. of weld length. Geometric analysis of web placement on chord shows available weld length in excess of required length. No check is required for tensile rupture (U=1.0).

Shown in Figure 4.2 is the detail for modifying the joist end.

Joist Marks: J22
Total Pcs: 1

Exist O.A.L.: 39'- 10 1/2"
Req'd O.A.L.: 39'- 00 1/2"

Work Description: Shorten joists 0'-10" by removing top chord at tag end.

Work performed at Tag End.

1. At bottom chord, cut existing end web 2" above top of angles.
2. At bottom chord, cut top chord back 10" removing web and chord bearings.
3. Place new bearing angles, 2 x 2 x 3/8 x 0'-4". Weld angles to top chords.
4. Place two (one each side) new end web members, 3/4" rounds. Provide a minimum of 2 1/4" of flare bevel weld at the end of each new end web (total of 4 1/2" for two rounds). Be sure to note placement of new end webs such that the working axis of the end webs is over the first bottom chord knuckle.

All weld to be made with E70XX electrodes.
 All fillet weld leg lengths equal to new angle thicknesses.
 All new material F_y= 36 ksi minimum.
 All welds to be performed by a welder certified to A.W.S. for welds and positions required.
 Sketches not to scale.

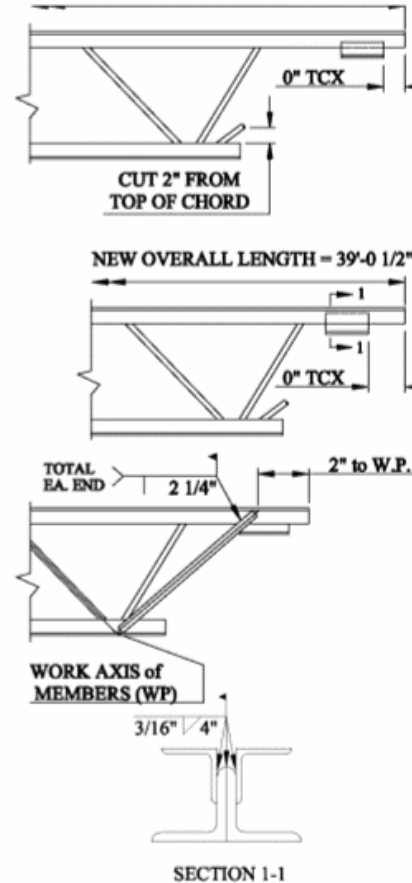

Figure 4.2 Reinforcing Detail

CHAPTER 5 OTHER CONSIDERATIONS

There are a number of other topics that need to be considered when making any type of joist modification.

1) Deflection

The joist can possibly be modified for added load, lengthened, or other alteration but the deflection criteria also needs to be taken into consideration. A live load deflection of less than L/240 may not be met if a joist is only strengthened for an added load from a snow drift.

2) Camber

When shortening or lengthening the camber needs to be maintained when removing any web members. If new joists are placed into an existing building keep in mind that they will also have camber and may be difficult to install if they are not supplied with shallower seat depths. They can be shimmed in the field.

3) Effects of Added Loads on Bridging

Depending on the type of modification being employed, the designer needs to investigate whether bridging needs to be added or altered. Providing lateral support to the compression chord members is critical. Keep in mind that the bottom chord may be subject to compression during wind uplift.

4) **Creating Two Joists from One**

Occasionally a joist needs to be cut near the center to make two joists from one (eg. possibly to make room for an added elevator shaft). When this is done it is similar to shortening a joist. Keep in mind that half of the new joist webs may need to be reinforced due to the increased shear they may now experience.

CHAPTER 6 SUMMARY

The SJI Technical Digest #12, **Evaluation and Modification of Open-web Steel Joists and Joist Girders**, provides more examples and information concerning the design approaches mentioned. This paper and the information in the digest does not include all possibilities not exclude other design issues that may pertain to the modification or repair of joists. It does, however, give the designer some ideas and methods that have been used successfully to modify joists.

REFERENCES

- AISC (2005), **Steel Construction Manual**, Thirteenth Edition, American Institute of Steel Construction, Chicago, IL.
- AISC (2005), *Specification for Structural Steel Buildings, March 9, 2005*, American Institute of Steel Construction, Chicago, IL.
- SJI (2003), **75-Year Steel Joist Manual**, Steel Joist Institute, Myrtle Beach, SC.
- SJI (2005), **42nd Edition Catalog** containing Standard Specifications, Load Tables and Weight Tables for Steel Joists and Joist Girders: **K-Series, LH-Series, DLH-Series, Joist Girders**, Steel Joist Institute, Myrtle Beach, SC
- SJI (2007), **Technical Digest 12, Evaluation and Modification of Open-Web Steel Joists and Joist Girders**, Steel Joist Institute, Myrtle Beach, SC.